

# 电涌保护器SPD

S-5-L2 Pro、S-24-L2 Pro  
S-5-L3 Pro、S-24-L3 Pro  
S-33-L2 Pro、S-60-L2 Pro  
P-24-L2 Pro



使用产品前请仔细阅读本说明书。

## 注意

请先确认收到的产品是否与订货合同一致。  
本产品安装、使用前应仔细阅读本说明书，若有疑问，请与本公司联系。  
严禁私自拆装产品，防止仪表失效或发生故障。

SISPD-PDCH-03H

## 功能原理图

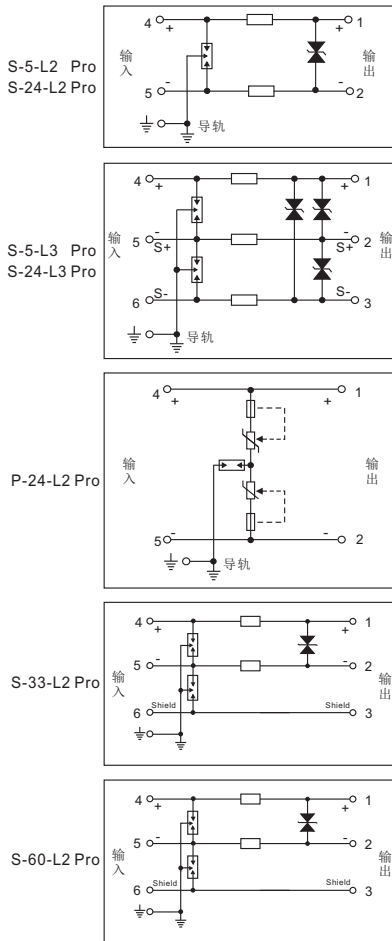

## 安装

使用SPD时必须要有可靠的接地，SPD采用DIN35mm导轨安装，建议使用铜制或钢制导轨。SPD安装步骤如图示。

- 1、把SPD底部上端金属件卡在导轨上；
- 2、把SPD底部下端金属件推进导轨。

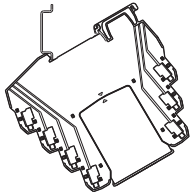

## 拆卸

SPD拆卸步骤如下图所示。

- 1、用一字螺丝刀(刀口宽度≤6mm)插入SPD底部金属导轨卡件凹槽内；
- 2、螺丝刀按下图所示方向向下压，将SPD底部金属导轨卡件向上撬起；
- 3、将SPD向上拉出导轨。

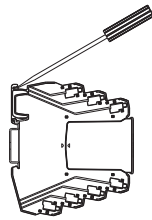

## 概述

该系列SPD主要用于保护以二线制、三线制方式连接的变送器、开关、频率信号、通信设备、热电阻、热电偶、FF和APL现场仪表、APL现场交换机、带RS485或RS232接口的设备等现场设备以及控制室DCS、PLC的I/O等设备，使其免受电涌或操作电压的破坏。



主要特点：  
热插拔，拔出后不断线  
导轨接地  
适用范围广

## 失效指示功能：

S-5-L2 Pro、S-24-L2 Pro、S-5-L3 Pro、S-24-L3 Pro电涌保护器，针对其内部最易损伤的防雷器件，设计了检测电路进行全生命周期监测，当失效发生时点亮LED进行报警指示。（需要接入具备驱动能力的信号回路，如：4mA-20mA）

## 外形尺寸(104×94.8×8mm)

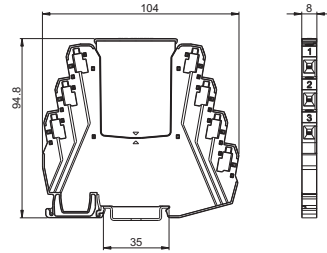

## 典型应用

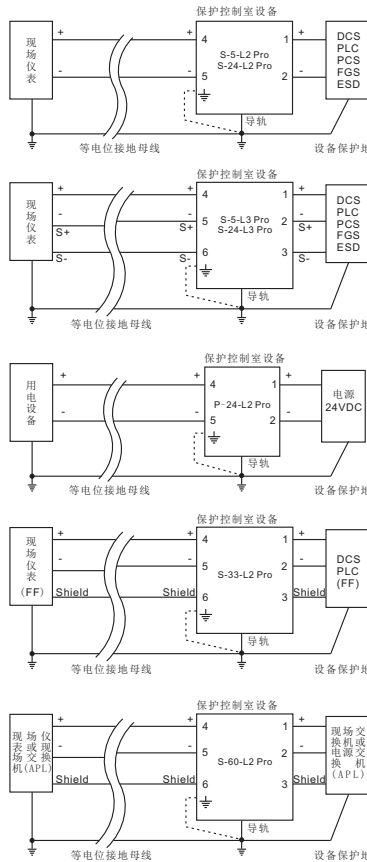

## 接线

该系列SPD采用M3螺丝接线，可连接截面积为0.5~2.5mm<sup>2</sup>(多股)或0.5~4mm<sup>2</sup>(单股)的铜导线；导线剥线长度为5~8mm。

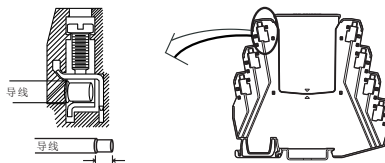

剥线长度：5mm≤L≤8mm 导轨接地线线径：4~6mm<sup>2</sup>

## 维护

- 1、SPD上电前，必须再次检查输入端与输出端的接线是否正确。
- 2、产品在出厂前均经过严格检验和质量控制，如发现工作异常，请及时与本公司联系。

## 主要技术参数

参数	型号 S-5-L2 Pro S-5-L3 Pro	S-24-L2 Pro S-24-L3 Pro	S-33-L2 Pro	S-60-L2 Pro	P-24-L2 Pro
额定工作电压Un	5VDC	24VDC	33VDC	58VDC	24VDC
最大工作电压Uc	8VDC	32VDC	36VDC	60VDC	36VDC
额定工作电流I <sub>n</sub>	600mA	600mA	600mA	1.25A	10A
冲击电流 I <sub>imp</sub> (10/350us)	2.5kA	2.5kA	2.5kA	2.5kA	/
通路电阻(线)	1Ω	1Ω	1Ω	0Ω	/
带宽(-0.5dB)	10MHz	10MHz	10MHz	10MHz	/
漏电流	<1μA	<1μA	<1μA	<1μA	<10μA
电压保护水平 Up	30V(L-L) 60V(L-G)	40V(L-L) 60V(L-G)	60V(L-L) 60V(L-G)	120V(L-L) 60V(L-G)	60V(L-L) 650V(L-G)

标称放电电流In(8/20us): 10kA  
最大放电电流Imax(8/20us): 20kA  
总放电电流I<sub>total</sub>(8/20us): 40kA  
响应时间: <1ns  
温度范围: -40℃~+80℃  
湿度范围: 5%~95%  
接线方式: 螺丝接线  
导线最大截面积: 2.5mm<sup>2</sup>  
安装方式: DIN 35mm导轨  
依据标准: GB/T 18802.21/IEC 61643.21

## 防爆认证

国家级仪器仪表防爆安全监督检验站(NEPSI)  
防爆合格证: GYB21.3287X  
防爆标志: Ex ia IIC T6...T4 Ga, Ex ec IIC T6...T4 Gc  
认证标准: GB/T 3836.1、GB/T 3836.3、GB/T 3836.4  
ia参数:

型号	Ui=6V	Ii=500mA	Pi=0.75W	T4: -40℃ ~ +80℃ T5: -40℃ ~ +75℃ T6: -40℃ ~ +60℃
S-5-L□ Pro				
S-24-L□ Pro	Ui=30V	Ii=200mA	Pi=0.95W	
S-33-L2 Pro	Ui=30V	Ii=500mA	Pi=0.84W	
S-60-L2 Pro	Ui=30V	Ii=500mA	Pi=0.84W	

## ec参数:

型号	额定电压	最大电流
S-5-L□ Pro	6V	500mA
S-24-L□ Pro	24V	500mA
S-33-L2 Pro	33V	500mA
S-60-L2 Pro	58V	1.25A
P-24-L2 Pro	24V	10A

## 环保声明

产品中有害物质的名称及含量

部件名称	有害物质					
	铅(Pb)	汞(Hg)	镉(Cd)	六价铬(Cr(VI))	多溴联苯(PBB)	多溴二苯醚(PBDE)
外壳和端子	×	○	○	○	○	○
电路板	×	○	○	○	○	○

本表格依据SJ/T 11364的规定编制。  
○: 表示该有害物质在该部件所有均质材料中的含量均在GB/T 26572标准规定的限量要求以下。  
×: 表示该有害物质至少在该部件的某一均质材料中含量超出GB/T 26572标准规定的限量要求，且目前业界没有其他成熟替代方案，有害物质浓度在RoHS指令豁免条款要求范围内，符合欧盟RoHS指令环保要求。  
20: 表示该产品含有某些有毒有害物质，在环保使用期限内可放心使用，超过环保期后应进入回收循环系统。

## 浙江中控自动化仪表有限公司 ZHEJIANG SUPCON INSTRUMENT CO.,LTD.

地址: 杭州市滨江区浦沿街道六和路309号 (310052)  
总机: 0571-86667888  
传真: 0571-86667711  
免费咨询热线: 400-887-6000  
E-mail: In\_sale@supcon.com  
网址: www.supcon.com www.supconauto.com

中控仪表 版权所有



151170223

# Surge Protective Device

S-5-L2 Pro, S-24-L2 Pro  
 S-5-L3 Pro, S-24-L3 Pro  
 S-33-L2 Pro, S-60-L2 Pro  
 P-24-L2 Pro



Before using the product, please read this manual.

### Caution

- Please check if product are consistent with the contract.
- Contact us if there is any question.
- Disassembling or repairing SPD is not allowed or it will cause malfunction.

SISPD-PDCH-03H

### Schematic Diagram

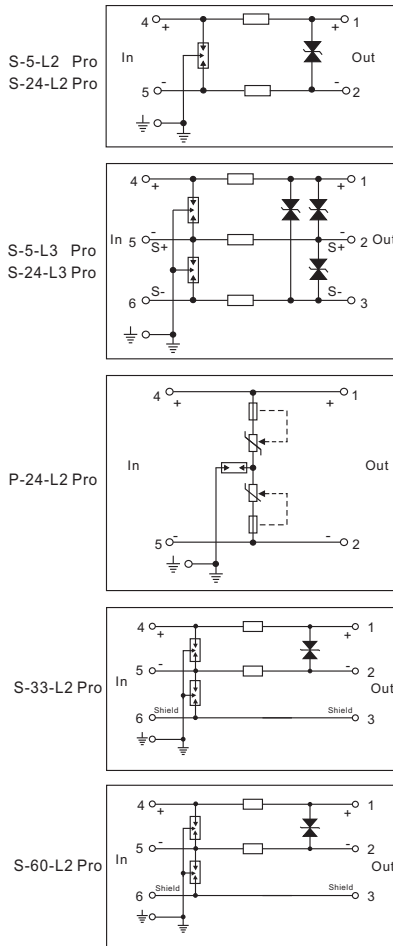

### Installation

When using SPD, there must be reliable grounding. SPD is fixed by DIN35mm rail. It is recommended to use copper or steel rail. SPD installation steps are below.

1. Make the upside of SPD's bottom locked into the rail.
2. Push the downside of SPD's bottom into the rail.

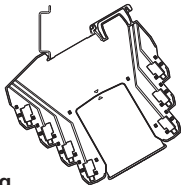

### Dismounting

Steps of dismounting SPD are shown in the figure below.

1. Insert a screwdriver (with an edge length ≤ 6mm) into the downside metal lock of SPD.
2. Push the screwdriver downwards as shown in following Figure and then rise up the bottom of SPD's metal buckle.
3. Take SPD out of the rail.

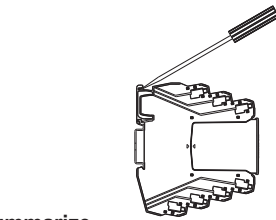

### Summarize

The series SPD can provide surge protection for field equipments such as sensors, transmitters, flow meters, solenoid valves, RTD, TC, FF and APL field meters, APL field switches, devices with RS485 or RS232 interface and for I/O interfaces such as AI, AO, DI, DO, TI, PI in PLC, DCS, FGS, ESD control systems.

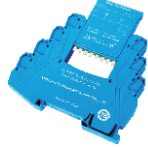

#### Main features:

- Surge protective modules can be replaced online without disconnecting the circuit.
- Easy grounding through DIN rail
- Wide range of applications

### Dimensions (104×94.8×8mm)

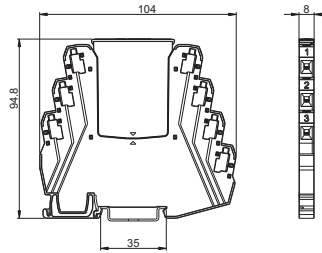

### Typical Application

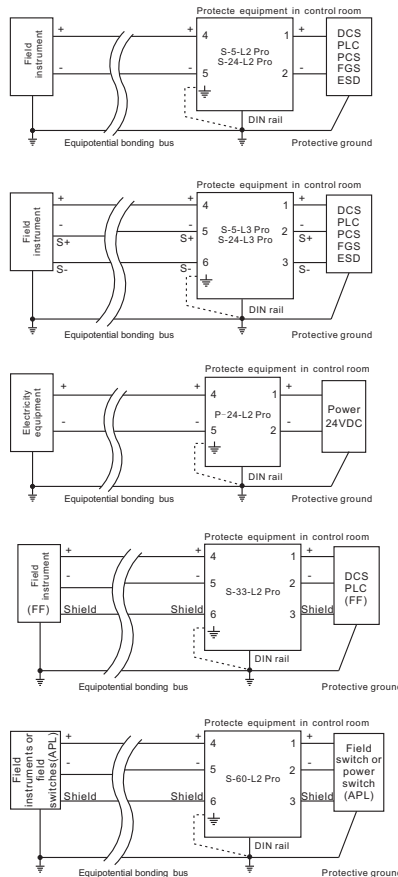

### Connections

M2.5 screws are used for SPD connection, which can connect copper wires with a cross-sectional area of 0.2 ~ 2.5mm<sup>2</sup> (multiple cables) or 0.2 ~ 4mm<sup>2</sup> (single cable); the wire stripping length is 5 ~ 8mm.

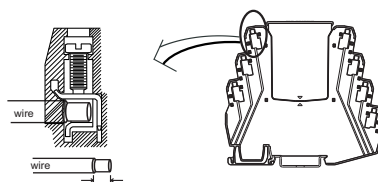

Stripping length: 5mm ≤ L ≤ 8mm

Cross-sectional area of rail grounding wire: 4.0-6.0mm<sup>2</sup>

### Maintain

1. Check if the connections are correct and tight before powering on SPD.
2. SPD's quality is well controlled and strictly inspected before delivery. If non-functional ones are found during operation, please contact us early enough.

### Technical Data

Type	S-5-L2 Pro S-5-L3 Pro	S-24-L2 Pro S-24-L3 Pro	S-33-L2 Pro	S-60-L2 Pro	P-24-L2 Pro
Rated operating voltage Un	5VDC	24VDC	33VDC	58VDC	24VDC
Max. operating voltage Uc	8VDC	32VDC	36VDC	60VDC	36VDC
Rated operating current I <sub>n</sub>	600mA	600mA	600mA	1.25A	10A
Impulse current I <sub>imp</sub> (10/350us)	2.5kA	2.5kA	2.5kA	2.5kA	/
Resistance(per line)	1Ω	1Ω	1Ω	0Ω	/
Bandwidth(-0.5dB)	10MHz	10MHz	10MHz	10MHz	/
Leakage current	<1μA	<1μA	<1μA	<1μA	<10μA
Protection level Up	30V(L-L) 600V(L-G)	40V(L-L) 600V(L-G)	60V(L-L) 600V(L-G)	120V(L-L) 600V(L-G)	600V(L-L) 650V(L-G)

Nominal discharge current I <sub>n</sub> (8/20us):	10kA
Max. discharge current I <sub>max</sub> (8/20us):	20kA
Total discharge current I <sub>total</sub> (8/20us):	40kA
Response time:	1ns
Temperature range:	-40°C~+80°C
Relative humidity:	5%~95%
Connections:	Screw connection
Max. sectional area:	2.5mm <sup>2</sup>
Installation:	DIN 35mm
Test standards:	GB/T 18802.21(IEC 61643-21)

### Ex Certification

National Supervision and Inspection Centre for Explosion Protection and Safety of Instrumentation  
 Certification No. : GYB21.3287X  
 Ex mark: Ex ia IIC T6...T4 Ga. Ex ec IIC T6...T4 Gc  
 Test standards: IEC 60079-0/IEC 60079-7/IEC 60079-11  
 ia parameters:

S-5-L□ Pro	Ui=6V	Ii=500mA	Pi=0.75W	
S-24-L□ Pro	Ui=30V	Ii=200mA	Pi=0.95W	T4:-40°C ~ +80°C T5:-40°C ~ +75°C T6:-40°C ~ +60°C
S-33-L2 Pro	Ui=30V	Ii=500mA	Pi=0.84W	
S-60-L2 Pro	Ui=30V	Ii=500mA	Pi=0.84W	

ec parameters:

S-5-L□ Pro	Rated voltage: 6V	Max. current: 500mA
S-24-L□ Pro	Rated voltage: 24V	Max. current: 500mA
S-33-L2 Pro	Rated voltage: 33V	Max. current: 500mA
S-60-L2 Pro	Rated voltage: 58V	Max. current: 1.25A
P-24-L2 Pro	Rated voltage: 24V	Max. current: 10A

### Environmental Declaration

Name and content of harmful substances

Part Name	Harmful Substance					
	Pb	Hg	Cd	Cr6+	PBB	PBDE
Housing and terminals	x	o	o	o	o	o
Circuit board	x	o	o	o	o	o

This form is prepared in accordance with the provisions of SJ / T11364.

o : Indicates that said hazardous substance contained in all of the homogeneous materials for this part is below the limit requirement of GB / T 26572.

x : Indicates that said hazardous substance contained in at least one of the homogeneous materials used for this part is above the limit requirement of GB / T 26572 and there is currently no mature alternative method in the industry. The concentration of hazardous substances is within the RoHS directive exemption clauses range, which meets the eco-friendly requirements of the EU RoHS directive.

Indicates that the product contains certain toxic and harmful substances, and it can be used within the eco-friendly period, and should be disposed by recycling after the environmental protection period is exceeded.

SUPCON GROUP CO.,LTD.

ZHEJIANG SUPCON INSTRUMENT CO.,LTD.

Address: No. 309 Liuhe Road, Puyan Street, Binjiang District, Hangzhou, Zhejiang, China, 310052.

Tel : +86-571-86667888

Fax: 0571-86667711

www.supcon.com www.supconauto.com

Copyright © All rights reserved by SUPCON

Surge Protective Device User Manual



151170223